

Autokap™

600 Series Single-Head Semi-Automatic Filler

The Autokap™ 600 series is part of the Rapak portfolio of cost effective filling equipment for liquids. Rapak's filling systems include semi-automatic and fully automated multi-heads for filling fresh and stable or sensitive liquids.

About

Autokap 600 series are single-head semi-automatic bag-in-box filling machines designed for a range of fresh or stable liquid products. Each filler is manually operated and designed to fill 1.5 to 20 liters at a lower production output. Bags are manually loaded into the filler and after filling, they are released onto the roller conveyor for loading into boxes.

Capacity

1.5 - 20 L bags (.5 gal. - 5 gal.)

Fully Pneumatic Operation

Simplified maintenance training

Fitment Compatibility

Compatible with a large range of fitments

Applications

The 600 series is designed for both hot and cold fill of product. It is ideal for an extended range of liquid products such as:

- wine
- water
- edible oil
- liquid dairy
- condiments
- chemicals
- post-mix syrup
- liquid egg

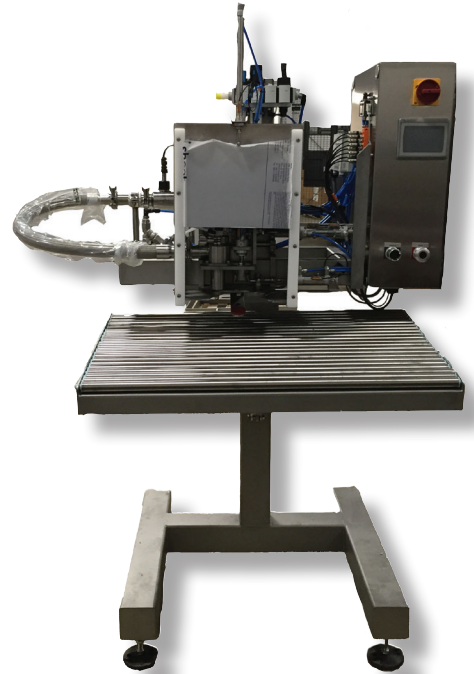

Standard Components

- Controls:** Allen-Bradley PLC / HMI
- Flowmeter:** 1.5" Turbine
- Filler Communication:** Ethernet
- Guarding:** Vertical Sliding Door
- Pneumatic Components:** Festo

Production Output

Production is dependent on product supply conditions. The rates below are based on filling water at 90 Gallons/minute (GPM) flow rate.

Volume L (gal.)	Flow Rate (BPM)
1.5 L (0.5 gal.)	8-9 bags/min
3 L (1 gal.)	8-9 bags/min
5 L (1.5 gal.)	7-8 bags/min
10 L (2.5 gal.)	6-7 bags/min
20 L (5 gal.)	5 bags/min

Construction

All fabricated components are made from stainless steel and engineering plastics. The filler surface finishes are designed to USA 3A Standards and European Hygienic Engineering & Design Group (EHEDG) Standards.

Utilities Required

- Power Supply:** 120 volts - Single phase, 10 amps
- Air:** 10 CFM at 80 psi, clean and dry, 3/8" NPT connection
- Water:** 3 gallons/minute (GPM) at 30 psi
- CIP/Flush:** 40-60 GPM, 1.5" Tri-clover connection, minimum 5 ft/sec velocity
- Product supply:** Standard 90 gallons/min. at 35 psi max; 1-1/2" tri-clover connection

Compliance

All Rapak fillers comply with UL/NEC Electrical Codes, OSHA Safety, FDA and 3A Regulations

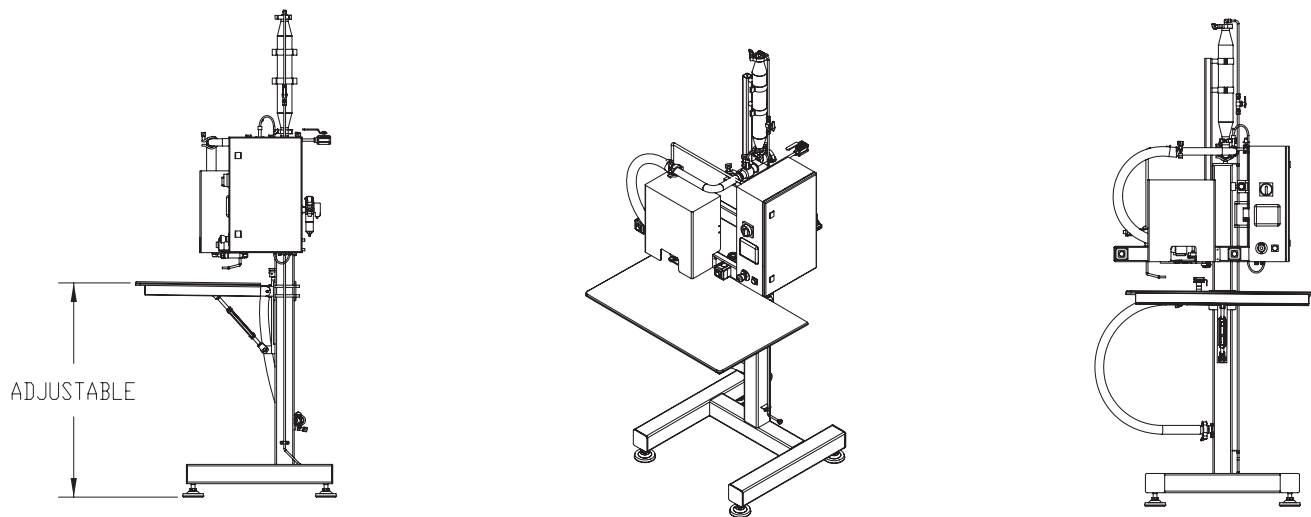

Learn more about the AutoKap filler at dssmith.com/rapak