

Strivo™

Strivo™, The Twist Lock, bag-in-box connecting system and complementing fitment offers ease of use with its simple connect, twist and lock functionality. Ideal for use when connecting flexible packaging to dispensing machinery, Strivo is suitable for high or low viscosity liquid beverages. It can also handle fruit aggregates.

Strivo's connector and fitment is a great fit for food products under FDA and EU regulations.

Features & Benefits:

- User-friendly
- Easy to clean and sanitize one piece construction
- Firmly locks into fitment
- Seals to keep product fresh

Part Number	ESL	Aseptic	Description
0505076	•	•	1/4 in. Lineside Connector *
0505073	•	•	1/2 in. Lineside Connector*
0502104	•		ESL housing
0501654		•	Aseptic housing

*connectors come in either 6 or 100 packs

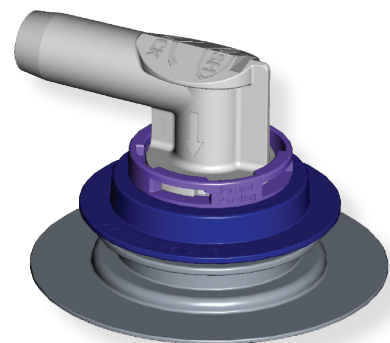
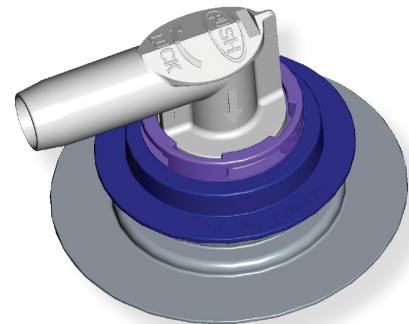
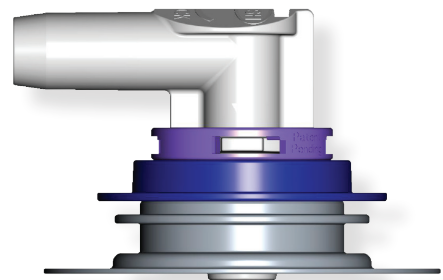

Item	Component	Material	Color
1A	1/2" Line Side Connector	Acetal	Grey
1B	Optional 1/4" Line side connector	Acetal	Grey
2	Disposable Dust Cap	LLDPE	White
3	Retaining Ring	PP	Natural
4	Silicone Valve	Silicone	Natural
5	ESL Housing (Aseptic Option Available)	LLDPE	Blue or Red Av.
6	Short or Tall Dairy Spout	LLDPE	Natural

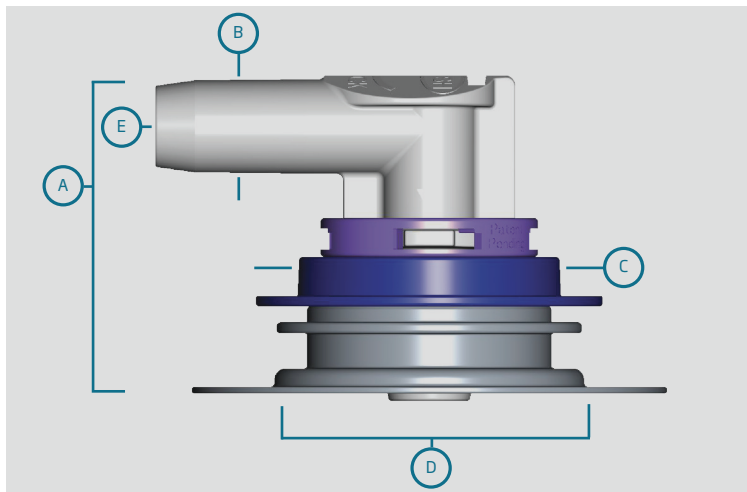

Feature ID	Feature Description	Dimensions
A	Overall Height	1.7"
B	Line Side Diameter	Ø.5"
C	Housing Diameter	Ø1.40"
D	Flange Diameter	Ø2.5"
E	Inside Dimension (1/2 in.)	Ø.375"
E	Inside Dimension (1/4 in.)	Ø.180"

